



CTV Armaturen & Penstocks GmbH



Gate Valve - Model 01J

Resilient seated - DN 32 - DN 600

NBR - Abwasser

EPDM - Trinkwasser

Compatibel DIN-DVGW-Zertifikat NW-6203CS0191



Available Pressures

PN 10
PN 16
PN 25

Product description (standard execution):

- Body bonnet and wedge made of ductile cast iron EN-GJS 400-15
- Full bore gate valve
- NBR/EPDM fully vulcanised wedge
- Application of low friction sliding element
- Wedge nut made of forged brass - replaceable
- Stainless steel spindle with rolled thread
- Low friction double spindle bearing acting both horizontal and vertical way
- O-ring spindle sealing packing cork protected against contact with medium
- Under pressure replaceable packing cork
- Forged packing cork protected against unscrewing
- Packing cork protected against dirt penetration
- Body bonnet Zinc coated screws protected by wax
- Epoxy coating minimum 250 microns according to EN ISO 12944-5
- Product according to EN 1074-1 and 2; 2002 EN 1171
- Flange connection according to EN 1092-2; (DIN 2501) pressure PN10; PN16
- Face to face according to EN 558-A1 F5 (DIN 3202) –
- Face to face according to EN 558-A1 F4 (DIN 3202) –
- Product marking according to EN 19; EN 1074

Execution variant:

Ductile cast iron EN-GJS 500-7
SS body and bonnet screws
With ISO top flange for actuator
With electric or pneumatic actuator - see.: 2901 2902 2903 2911
With inductive or electromechanical sensor
With opening indicator
Other material variants on request!

Application:

Water and sewage networks and tanks. Transport of non aggressive liquids.
Working conditions:
temp. up +70°C
pressure up to 1,6 MPa

Test control:

Hydraulic test according to EN 1074-1; EN 1074-2; EN 12266-1
Seat: 1,1 xPN
Body: 1,5 x PN
Operation torque test.



CTV Armaturen & Penstocks GmbH

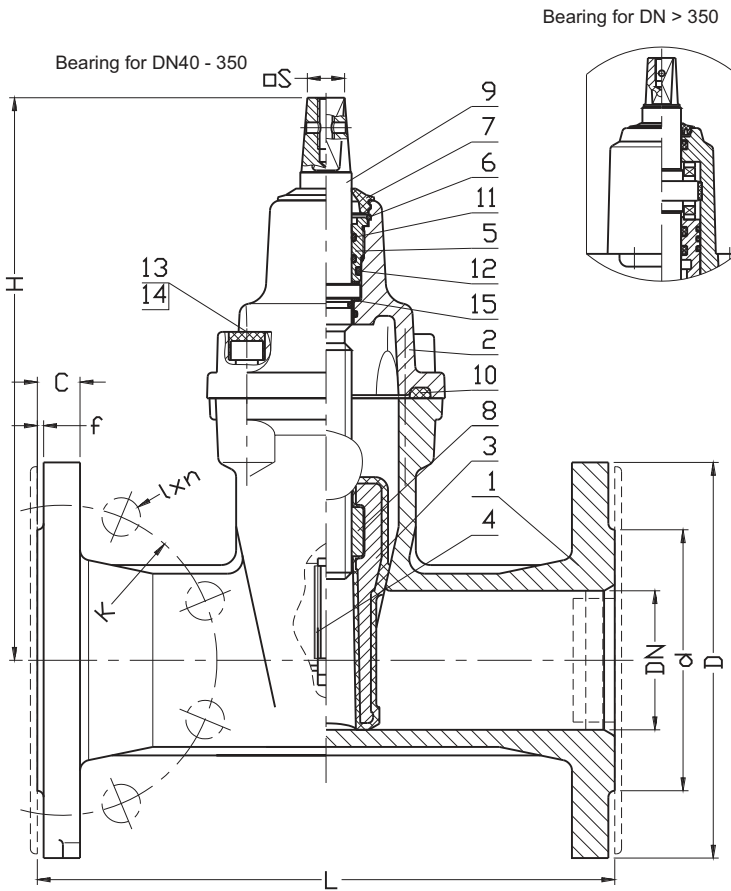

No.	Part	Standard execution
1	Body	Ductile cast iron EN-GJS-400-15 or EN-GJS-500-7 EN 1563
2	Bonnet	Ductile cast iron EN-GJS-400-15 or EN-GJS-500-7 EN 1563
3	Wedge	Brass acc. to EN 1982 (DN32) Ductile cast iron (DN40-DN600) EN-GJS-400-15 or EN-GJS-500-7 EN 1563 Rubber EPDM NBR EN ISO 1629
4	Wedge slider	Poly amide EN ISO 1874-1
5	Packing cork	Brass EN 1982
6	Protection ring	Steel 1.1260
7	Cleaning gasket	Rubber EPDM or NBR EN ISO 1629
8	Spindle nut	Brass EN 1982
9	Spindle	Stainless Steel AISI-420 (1.4021) Optional: Stainless Steel 316 (1.4401)
10	Body-bonnet gasket	Rubber EPDM or NBR EN ISO 1629
11	O-ring	Rubber EPDM or NBR EN ISO 1629
12	O-ring	Rubber EPDM or NBR EN ISO 1629
13	Screw	Steel Fe/Zn5, stainless steel EN ISO 4762
14	Screw stopper	Wax
15	Washer	Poly amide PA6 EN ISO 1874-1

- other material variants on special request

DN	F4 L	F5 L	H	d PN16 (PN10)	D PN16 (PN10)	K PN16 (PN10)	I PN16 (PN10)	C	f	n PN16 (PN10)	Turns for full open	S	Weight F4 [kg]	Weight F5 [kg]
[mm]														
32	130	140	145	76	140	100	19	18	3	4	9	12	5	6
40	140	240	220	84	150	110	19	19	3	4	11	14	9	10
50	150	250	230	99	165	125	19	19	3	4	13,5	14	10	11
65	170	270	265	118	185	145	19	19	3	4	14	17	14	16
80	180	280	290	132	200	160	19	19	3	8	17	17	15	17
100	190	300	325	156	220	180	19	19	3	8	21	19	21	23
125	200	325	365	184	250	210	19	19	3	8	26	19	31	39
150	210	350	457	211	285	240	23	19	3	8	26	19	41	48
200	230	400	534	266	340	295	23	20	3	12 (8)	34,5	24	62	77
250	250	450	633	319	405	355 (350)	28 (23)	22	3	12	42,5	27	94	106
300	270	500	708	370	460	410 (400)	28 (23)	25	4	12	51	27	122	148
350	290	550	790	429	520	470 (460)	28 (23)	27	4	16	60	27	216	254
400	310	600	1020	480	580	525 (515)	31 (28)	28	4	16	58	32	298	345
450	330	-	1090	548 (530)	640	585 (565)	31 (28)	30	4	20	65	32	350	-
500	350	700	1220	609 (582)	715 (670)	650 (620)	34 (28)	32	4	20	63	36	458	540
600	390	800	1390	720 (682)	840 (780)	770 (725)	37 (31)	36	5	20	77	36	640	776

*DN800-DN1200 on request